



**Aplicações de 3D e
Realidade Aumentada**

Agenda

1. Introdução
2. Aplicações
3. Etapas
 - a. Modelagem
 - b. Texturização
 - c. Animação
 - d. Renderização
4. Demo

1. Introdução



HoloLens (2016 — 2018)



iOS / Android AR apps
(2018)



Web AR (2019 —)



CGI (2020 —)

O que fazemos

Desenvolvemos
soluções revolucionárias
e escaláveis de
conteúdo digital
para o seu produto

Modelagem 3D e
Realidade Aumentada
feita para a cadeira
gamer Ônix Diamond
da DT3



Experimente nossa Realidade Aumentada!

**Sugerimos o acesso com Iphone 6S/superior
ou Android 8/superior para melhor experiência.*



Aplicações

2. Aplicações

Filmes e séries



Game of Thrones (2019)



Avengers: Infinity War (2018)

2. Aplicações

Jogos



Lumen in the Land of Nanite (2020)



Quake (2010)

2. Aplicações

Propaganda

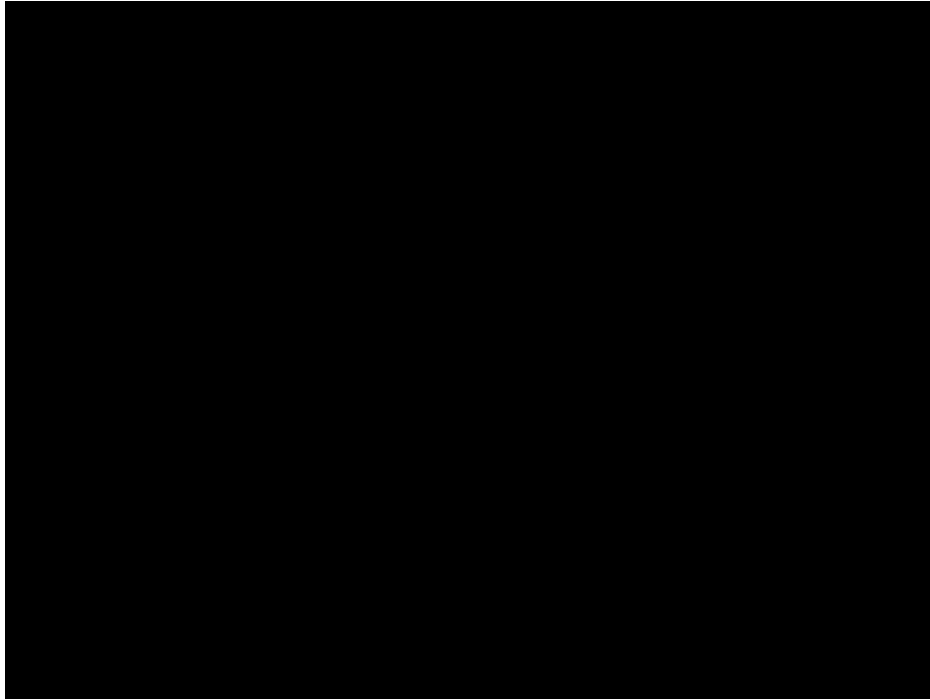

Nike "Awaken The Phantom" (2018)

2. Aplicações

Visualização Arquitetônica



NoTriangleStudio 3D Architectural Renderings

2. Aplicações

Simulações

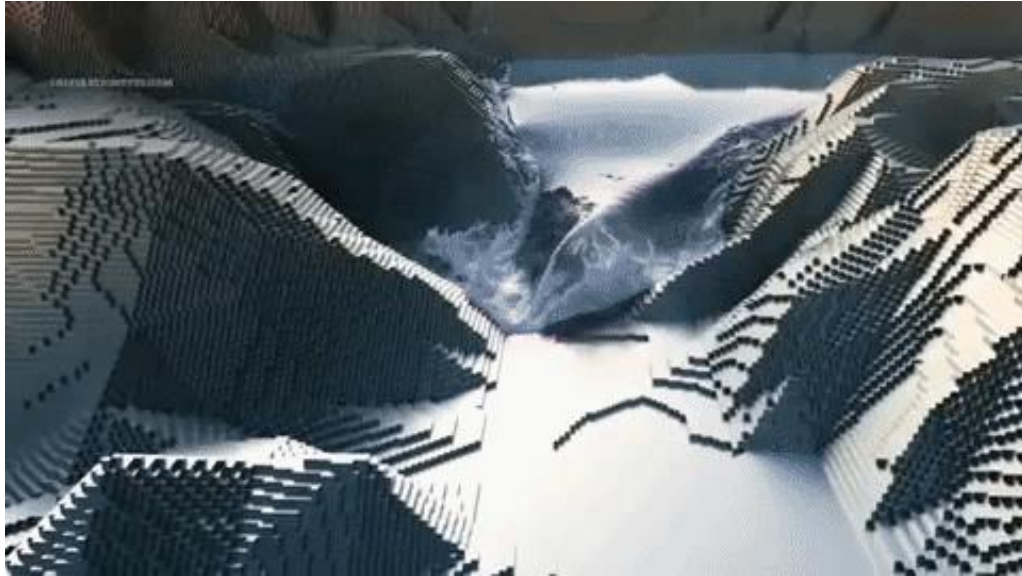

Blender Fluid Simulation

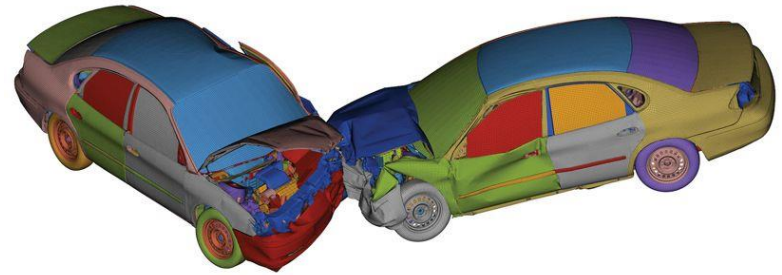

Crash Simulation

Etapas

Modelagem
Texturização
Animação
Renderização

3. Etapas

Modelagem

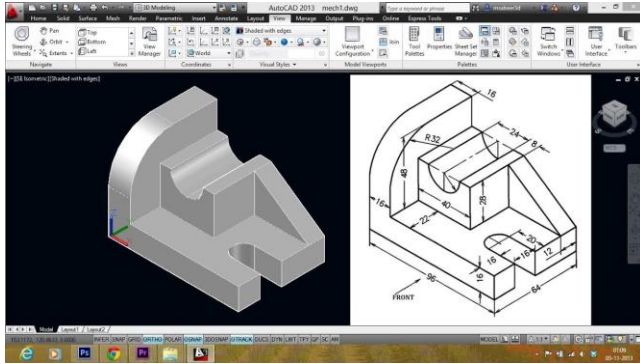

CAD

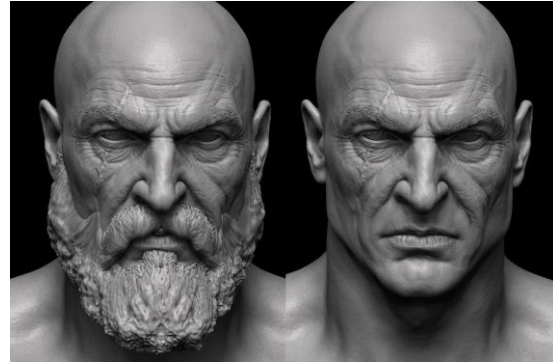

Escultura

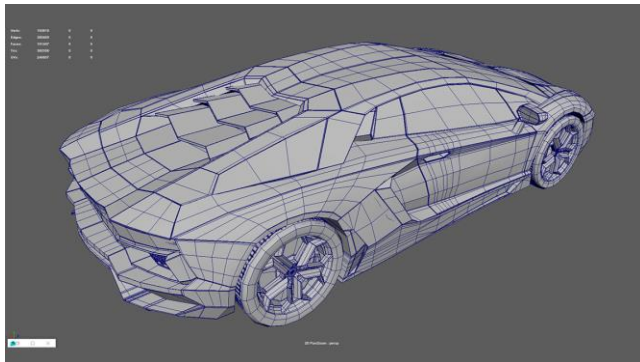

Poligonal

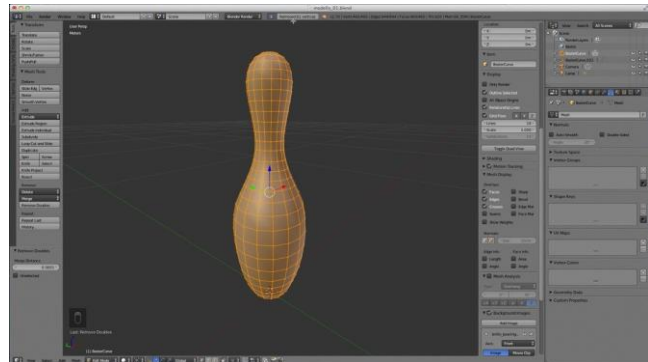

Curvas

3. Etapas

Texturização

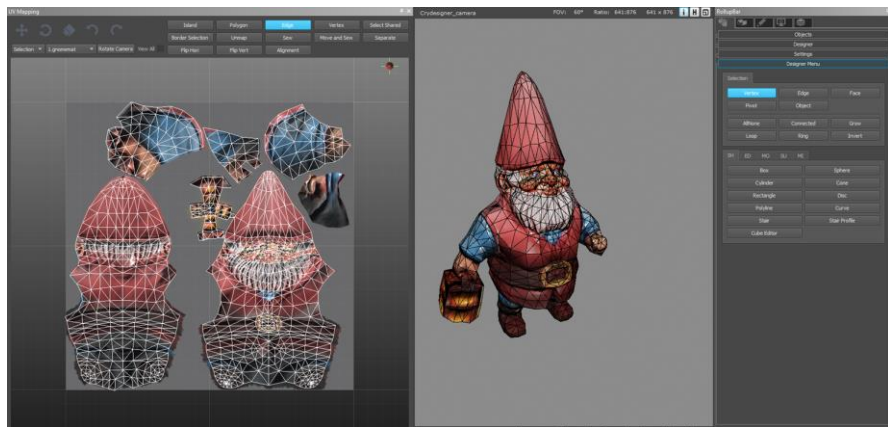
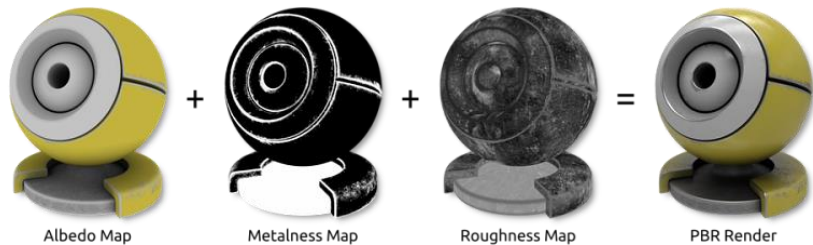

Mapeamento UV

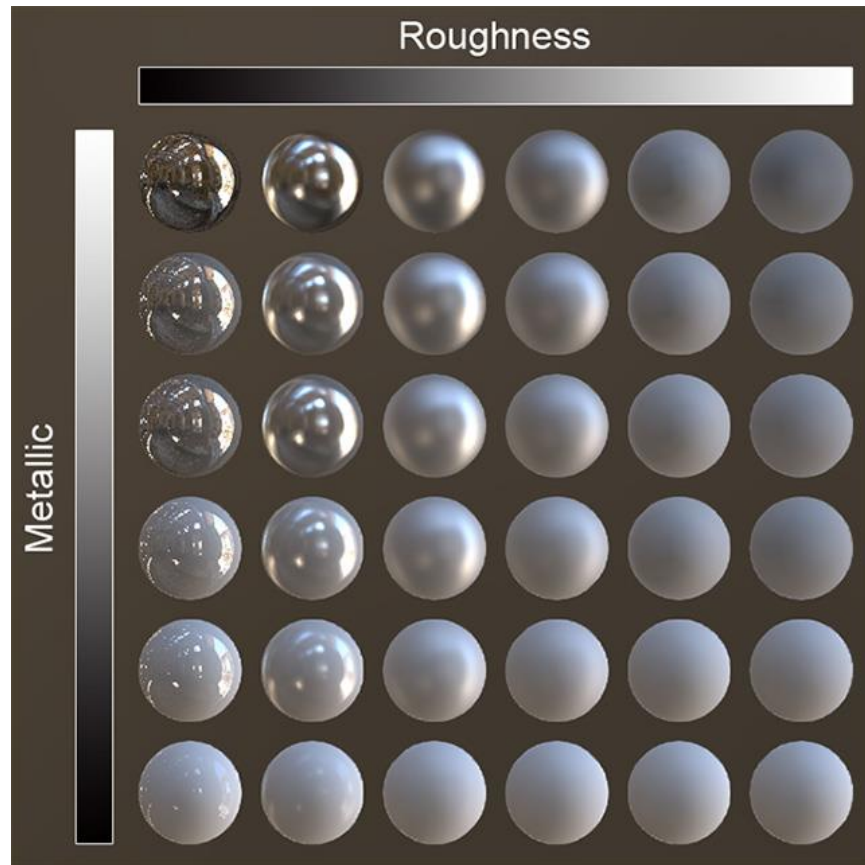

3. Etapas

Animação

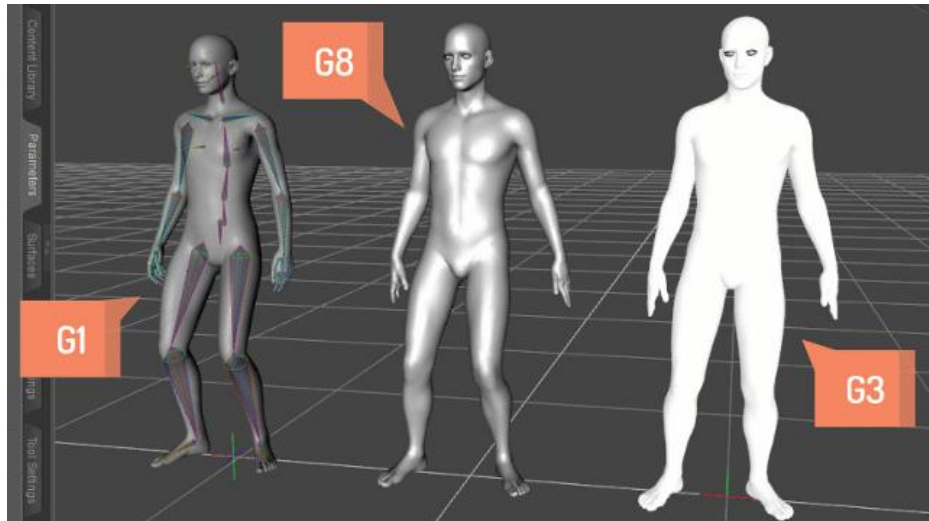

Rigging, Skinning, Animação

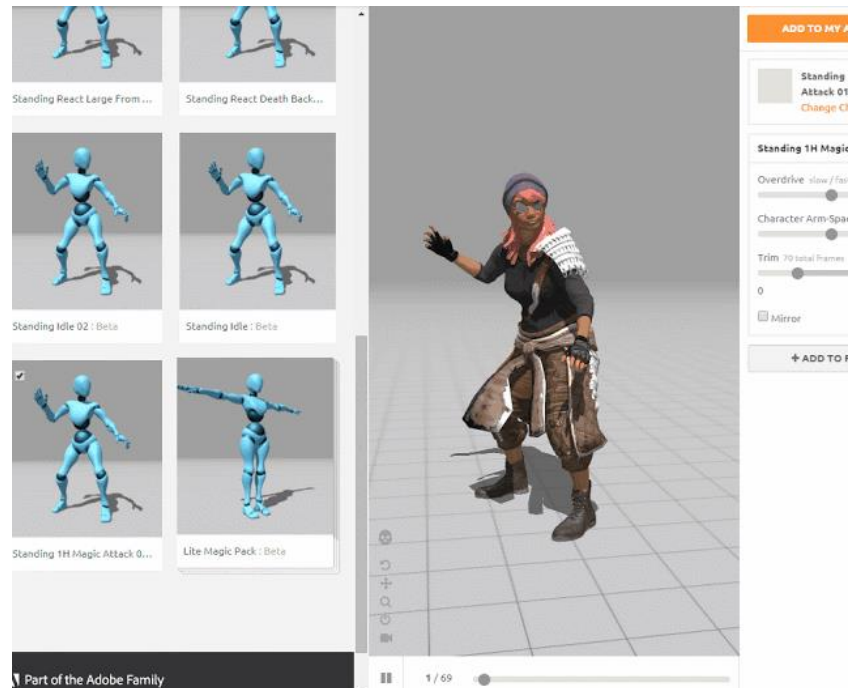

3. Etapas

Renderização





Demo

R2U

jobs@r2u.io

caio@r2u.io

Bibliografia

Link da apresentação <https://bit.ly/3d-realidade-aumentada>

- [3D modeling](#)
- [Computer animation](#)
- [3D rendering](#)
- [PBR rendering](#)
- [Animation Boss](#)
- [Google Poly](#)
- [Aston Martin](#)
- [Poliigon](#)

- [Demo final](#)